



NORTHEAST POWER COORDINATING COUNCIL, INC.  
1040 AVE OF THE AMERICAS, NEW YORK, NY 10018 TELEPHONE (212) 840-1070 FAX (212) 302-2782

## NPCC Request for Criteria Clarification

**Note: a Clarification cannot be used to revise the Criteria within a Directory.**

Request for a Clarification of Criteria
Date submitted: December 1, 2017 Date revised version submitted: n/a
<b>Contact information for person requesting the clarification:</b>
Name: <a href="#">Alan Adamson</a>
Organization: <a href="#">New York State Reliability Council (NYSRC) Reliability Rules Subcommittee</a>
Telephone: <a href="#">352-989-4653</a>
E-mail: <a href="mailto:aadamson@nycap.rr.com">aadamson@nycap.rr.com</a>
<b>Identify the Directory that contains the Criteria requiring clarification:</b>
Directory Number: <a href="#">Directory 1</a>
Directory Title: <a href="#">Design and Operation of the Bulk Power System</a>

## Identify specifically what portion of the Criteria needs clarification:

Text of Requirement: [Table 1 Planning Design Criteria: Contingency events, Fault type and Performance requirements to be applied to Bulk Power System elements; Category II Event\(s\) after a first loss and after System Adjustment:](#)

Category	Contingency events	Fault type (permanent)	Performance requirements
	Simulate the removal of all elements that protection systems, including <b>Special Protection Systems</b> , are expected to automatically disconnect for each event that involves an AC fault.	On the listed <b>elements</b> where applicable	
<b>II</b> Event(s) after a first loss and after System Adjustment	1. Following the loss of any critical: a. transmission circuit, b. transformer, c. series or shunt compensating device or d. generator e. Single pole of a direct current facility and after System Adjustment, Category I Contingencies shall also apply.	Any Category I event as described above.	Performance requirements i to viii apply  Area generation and power flows are adjusted between outages by the use of resources available within ten minutes following notification and other system adjustments such as HVDC and phase angle regulator adjustments that can be made within 30 minutes.

There may be a design gap in the NPCC Directory 1 [Table 1 Planning Design Criteria: Contingency events, Fault type and Performance requirements to be applied to Bulk Power System elements.](#)

In particular, [Table 1 Category II \(Event\(s\) after a first loss and after System Adjustments\)](#) does not contemplate N-1/-1 events where:

- The first contingency (N-1) being: Opening of any circuit breaker;
- The second contingency (N-1/-1) being: (Following N-1) Opening of any circuit breaker (not related to clearing action of the allowable [Table 1 Category I Contingencies](#)).

Under such N-1/-1 events, a high capacity injection (ex.: AC transmission, HVDC, or a generating unit) can be isolated onto a low rated transmission circuit (possibly loading it above its LTE or even its STE rate). Please see [Figure 1](#) below:

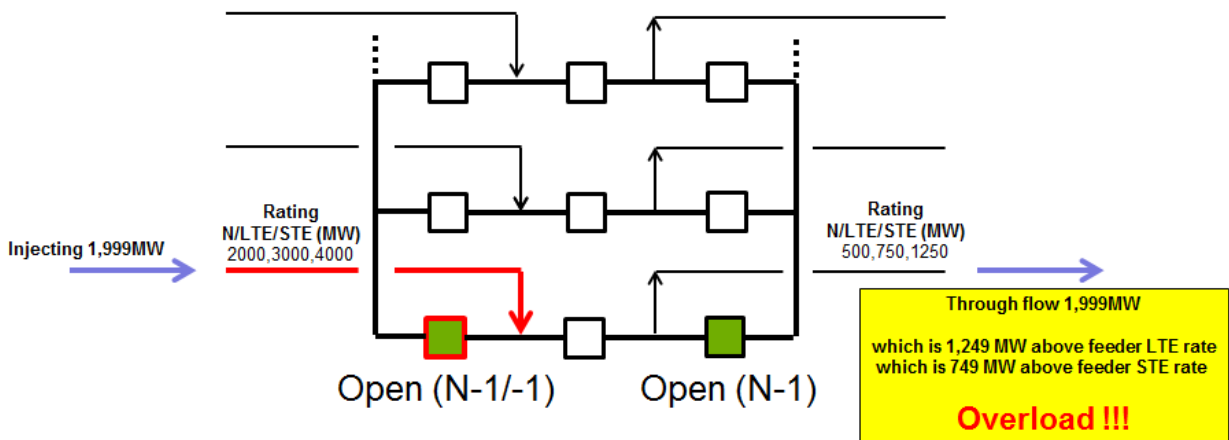

Figure 1

Clarification #1 requested by the NYSRC:

1. Why does NPCC Directory 1 omit N-1/-1 event such as open breaker followed by an open breaker?

A possible solution to the identified scenario above (Figure 1)\* could be to open the middle breaker as a "system adjustment" within 30 minutes before the second contingency (in effect tripping the low rated transmission circuit). This action would eliminate the postulated overload illustrated in Figure 1.

Clarification #2 requested by the NYSRC:

2. Does NPCC Directory 1 postulate that the opening up of a circuit breaker falls within the definition of a "system adjustment"?

*\* beyond "Area generation and power flow are adjusted between outages by the use of resources available within 10 minutes following notification and other system adjustments such as HVDC and phase angle regulator adjustments that can be made within 30 minutes".*

### **Identify the material impact associated with the lack of clarity:**

Identify the material impact to your organization or others caused by the lack of clarity or an incorrect interpretation of this Directory:

An incorrect interpretation of NPCC Directory 1 requirements could result in improper design of the Bulk Power System.

Task Force Response to Request for Criteria Clarification:  
Criteria Clarification  
Directory #1 for the New York State Reliability Council (NYSRC) Reliability  
Rules Subcommittee

The following clarification of the criteria in [Directory# 1 Design and Operation of the Bulk Power System](#) was developed by the Task Force on Coordination of Planning in coordination with the Task Force on Coordination of Operation.

**Question 1**

Why does NPCC Directory 1 omit N-1/-1 event such as open breaker followed by an open breaker?

**Response to Question 1**

Planning scenarios in Table 1 are not expected to test all operating scenarios. The planning requirements in Directory 1 are used for the design and planning of the power system, while the operations requirements are applicable to operations scenarios. In the de-scribed scenario, after the first breaker opens, available control actions for operators such as opening a breaker or even taking a line out of service would result in a configuration that is covered by planning criteria.

**Question 2**

Does NPCC Directory 1 postulate that the opening up of a circuit breaker falls within the definition of a "system adjustment"?

**Response to Question 2**

While not specifically mentioned in Directory 1, opening up of a circuit breaker is a system adjustment to be considered in planning timeframe, provided it can be implemented within 30 minutes.